

# Techniques for classification sonar: rocks vs. mines

Baida'a Abdul-Qader  
Computer Science Department, IT, Basrah University  
email: baida0307@gmail.com

**Abstract:** This work is concerned with a process of distinguishing between metal cylinder (mines) and materials that have a cylindrical shape (rocks) by using sonar images or signals. Three techniques were used. They were: Neural Networks, Adaptive Neuro-Fuzzy Inference System and k-Nearest Neighbor, by using (before and after) one of the most feature selection procedure widely used which is called Sequential forward selection (SFS) to reduce the data dimensions.

The data which were used in this work, were taken from UCI machine learning repository. The high generalization has been achieved on the selected features by applying SFS method. This work was implemented in MATLAB 7.0 environment.

**Keywords:** Neural Network, Adaptive Neuro-Fuzzy Inference System, k nearest neighbor, Sequential forward feature selection.



## 1. Introduction

In a learning and statistics machine, **feature selection** is the process of selecting a subset of features to be used in model construction. Feature selection techniques were used for three reasons as follow:

- To simplify the models.
- To reduce training time,
- to enhanced generalization.

The feature selection has been widely used to reduce the data dimensionality. Data reduction improve the classification performance, the approximation function, and pattern recognition systems in terms of speed, accuracy and simplicity. A strategy to reduce the number of features in local search are the sequential search algorithms [1].

Artificial Neural Networks [2,3] is one of the artificial intelligent techniques commonly used, because of its ability to capture and represent complex input and output relationships among data.

Neural networks are composed of simple elements operating in parallel. These elements are inspired by biological nervous systems. As in nature, the network function is determined mainly by the connections between elements. It is used in various fields of application including pattern recognition, identification, speech, vision, classification, and control systems.

The advantage of the fuzzy inference system is that it can deal with linguistic expressions and the advantage of a neural network is that it can be trained and so can self-learn and self-improve. Jang in 1993 took both advantages, combining the two techniques, and proposed the Adaptive Neuro-Fuzzy Inference System (ANFIS). The idea behind neural network and fuzzy inference combination is to design a system that uses a fuzzy system to represent knowledge in an interpretable manner and has the learning ability derived from a neural network that can adjust the membership functions parameters and linguistic rules directly from data in order to enhance the system performance [4].

k-Nearest Neighbor (kNN) classification is one of the most fundamental and simple classification methods, although it can also be used for estimation and prediction. It was developed from the need to perform discriminant analysis when reliable parametric estimates of probability densities are unknown or difficult to determine. It provides good performance for optimal values of k. [5,6]

This paper is structured as follows: section 2 is a review of the basic concepts of neural networks, adaptive Neuro-fuzzy inference system and kNN. Section 3 explains sequential forward feature selection method. Dataset description is described in section 4, while the description of this work is described in section 5. Results are discussed in section 6 and section 7 shows the conclusions.

## 2. Basic concepts

Neural Network includes connections (called weights) between neurons Input and Output Target. The supervised training methods are commonly used, but other networks can be obtained from unsupervised training techniques or from direct design methods. Neural Network trainsto perform a particular function by adjusting the weights, based on a comparison of the output and the target, until the network output matches the target. This operation is shown in figure 1 below. In feeding forward, multi-layer neural network with training algorithm functional signals flows in forward direction and error signals propagate in backward direction. The activation function is chosen for hidden and output layer computational neurons. The algorithm is based on error-correction rule. The rule for changing values of synaptic weights follows generalized delta rule. [4]

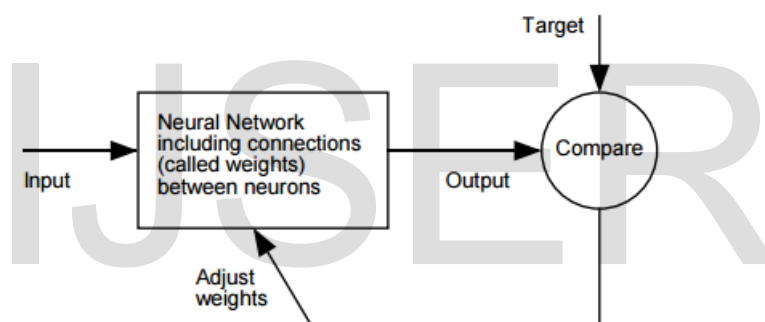

Figure (1) Operation of neural network

ANFIS is a hybrid intelligent system which implements a Sugeno fuzzy inference system for a systematic approach to generating fuzzy rules from a given input-output dataset, the architecture contains a five-layer feedforward neural network as shown in Figure(2)[4].

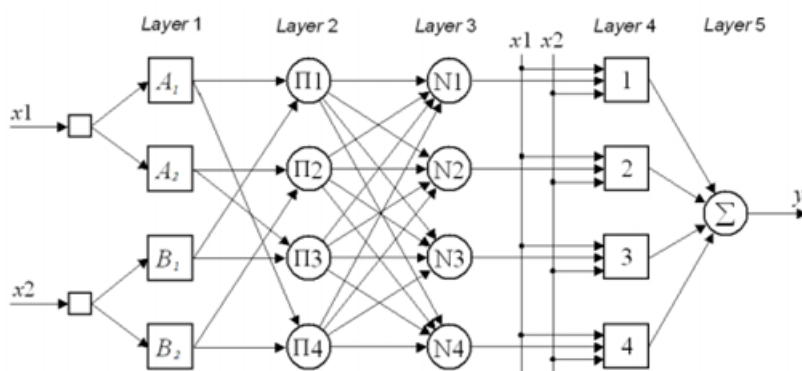

Figure (2) Adaptive Neuro-Fuzzy Inference System(ANFIS)

In this work, ANFIS is applied to generate a FIS aSugeno-type FIS structure from using fuzzy c-means (FCM) clustering by extracting a set of rules that models the data behavior. The input membership function type is Gaussian membership function and the linear membership function type for output.

The k-nearest neighbors algorithm is a method for classifying objects based on closest training examples in the feature space, where kNN classification divides data into a test set and a training set. For each row of the test set, the k nearest (in Euclidean distance) training set objects are found, and the classification is determined by majority vote with ties broken at random. If there are ties for the kth nearest vector, all candidates are included in the vote[7,8].

### 3. Sequential forward feature selection

Sequential forward selection is one of the most widely used procedures in feature selection and it is a bottom-up search procedure that adds new features to a feature set one at a time until the final feature set is reached, where SFS will be return a subset of features based on their rank.

Algorithm: Suppose we have a set of  $d_1$  features,  $X_{d_1}$ , at start is empty set, For each of the features  $\xi_j$  not yet selected (i.e. in  $X - X_{d_1}$ ) the following criterion function is evaluated:

$$J_j = J(X_{d_1} + \xi_j)$$

The feature that yields the maximum value of  $J_j$ s chosen as the one that is added to the set  $X_{d_1}$ . Thus, at each stage, the variable is chosen that, when added to the current set, maximizes the selection criterion. The algorithm terminates when the maximum allowable number of features is reached[1].

#### 4. Dataset description

The data set contains 208 patterns, 111 patterns obtained by bouncing sonar signals off a metal cylinder at various angles and under various conditions and 97 patterns obtained from rocks under similar conditions. The data set contains signals obtained from a variety of different aspect angles, spanning 90 degrees for the cylinder and 180 degrees for the rock. Each pattern is a set of 60 numbers in the range 0.0 to 1.0. Each number represents the energy within a particular frequency band, integrated over a certain period of time. The label associated with each record contains the letter "R" if the object is a rock and "M" if it is a mine (metal cylinder)[9].

In this work, the output "R" and "M" were changed to 1 and 0 respectively, while 208 patterns were divided into 104 patterns as training set and the 104 patterns as testing set.

#### 5. Work description

The work in this research is described in the following points and figure (3) :

1. Prepare training - testing data as follow: choose randomly 104 patterns for training and 104 patterns for testing. Each pattern consists of 60 features.
2. Apply and record the results on three techniques:
  - a. In neural network, A standard back-propagation network was used for all experiments. The network had 60 inputs 1 output unit, one indicating a cylinder and the other a rock. The reported performance is the best of 5 runs.

- b. In kNN, to find best k, apply k-NN for the data set on k values ranges from 1 to 30.
- c. In ANFISs, generate Fuzzy Inference System structure from data using FCM clustering, the number of clusters are selected randomly.

3. Apply Sequential forward feature selection for ranking 60 features of the data set, then resort the data set according to that (see appendix A).

4. In order to determine which features that very important and have more a significant effect on performance, we apply one technique that has behavior not randomly, kNN technique with k=1 many times with different sequences of features, in each case we recorded the performance (testing rate) as it is shown in Appendix B, the testing rate is calculated as follow:

$$\text{Testing rate} = (\text{correct patterns} / 104) * 100$$

The results show that features 5-54 (in appendix B) give high generalization comparing with other cases.

- 5. Prepare new data set for training-testing with selected features (50 features).
- 6. Repeat point 2 with new training-testing data set.

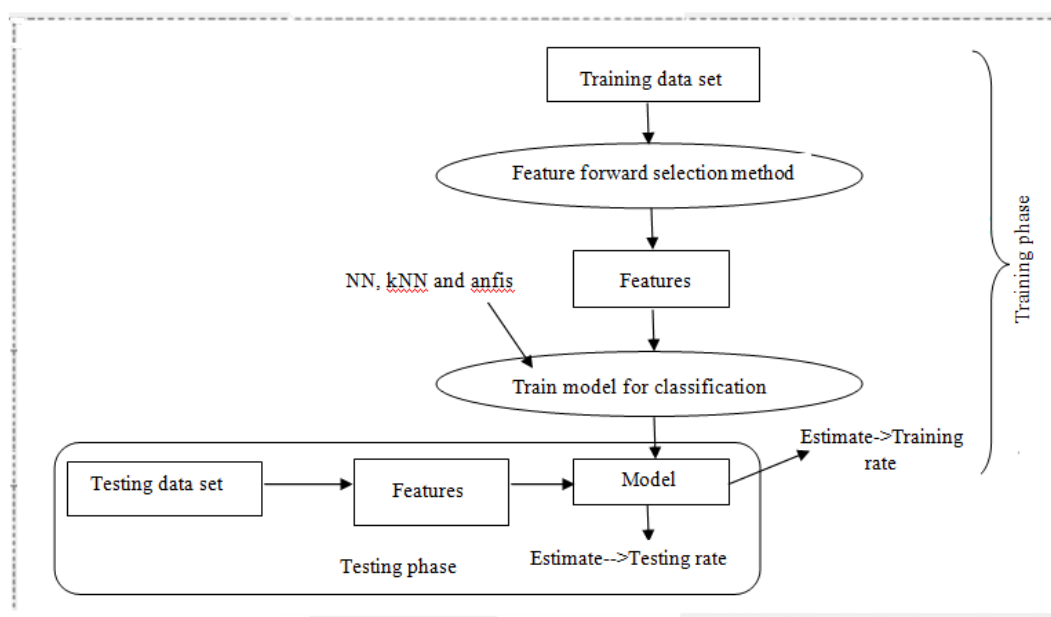

Figure (3) The process of classification of rock and mine problem

## 6. Simulation and Results

The simulation process of the systems : neural network, ANFISs, kNN and SFS were carried out using MATLAB (R2008a).

To train neural network, Matlab function train( ) was used, 50% of data for training and 50% for testing. Traingdm, learnngdm and tansig are used as a training function, learning function and transfer function respectively. Number of hidden layers =4 and learning will stop when epochs= 4000 The best performance is achieved when learning rate=0.001. Table (1) shows the best properties for backpropagation neural network in order to build a classifier for our problem and table (2) shows the results for 5 runs of neural before and after ranking the features, the mean square error for the best run is shown in figure(4).

Table (1) prosperities to build neural network for our problem

Neural network prosperities	value
Number of hidden layer	4
Number of hidden neuron	150
Transfer function	tansig
Learning rate	0.001
Training technique	Gradient with backpropagation
Epochs	4000
Training patterns	104
Testing patterns	104

Table (2) Training rate and test rate for neural network

	Run no.	1	2	3	4	5

Before features ranking	Training rate	100%	100%	99.04%	100%	100%
	Testing Rate	74.04%	73.08%	-	64.42%	75%
	Network Error	0.03	0.05	-	0.06	0.007
After features ranking	Training rate	100%	100%	100%	100%	100%
	Testing Rate	76.92%	86.5%	89.42%	81.73%	83.65%
	Network Error	0.013	0.001	0.0025	0.03	0.019

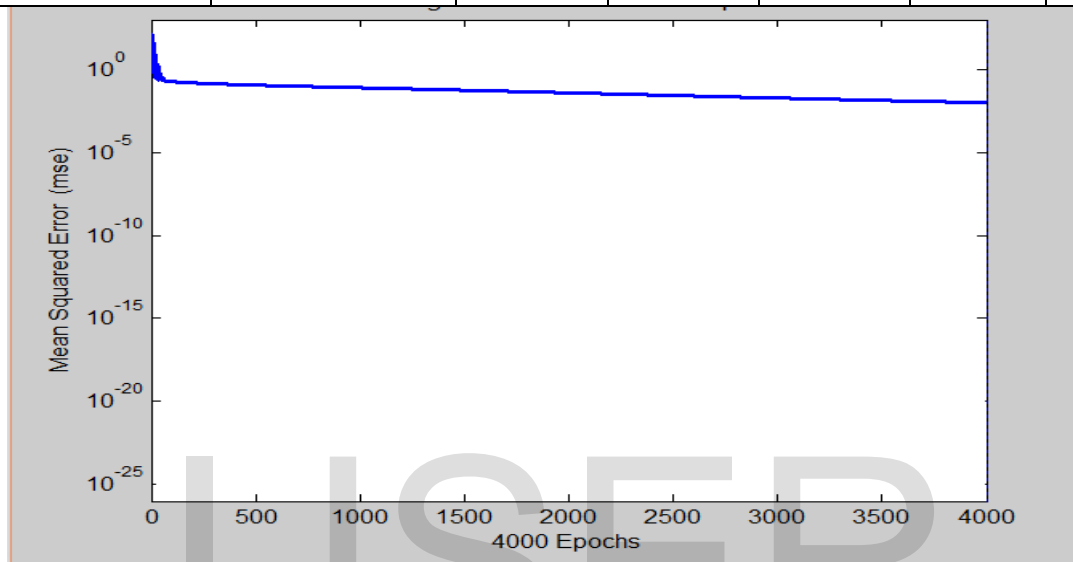

Figure (4) Mean Square Error for best run in case NN after ranking the features

To train kNN, for measure distance we used the most common function: Euclidean distance, 104 patterns for sample and 104 for training, while the value k was used to test varying values(1-30) .Figure (5) shows testing rate with different values of k before ranking the features, as it is shown except the first two (k=1 or 2), most testing rates associated with the varying k values are low rating. Table(3) shows testing rate for 10 values 1-10 of k before and after apply SFS method on dataset.



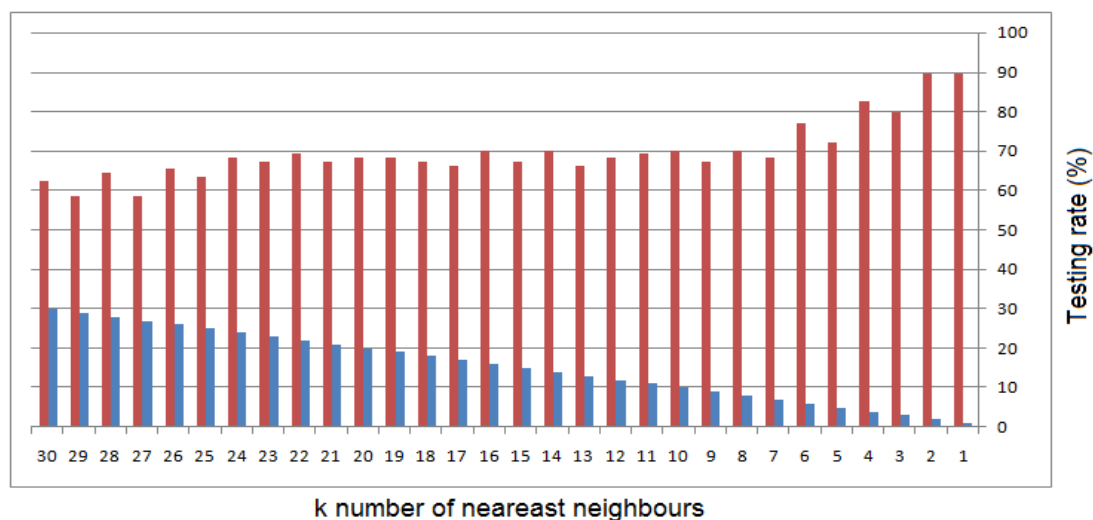

Figure (5) Testing rate with varying values of k

Table (3) Effective of the 10 values of k in knn

K	Without ranking	With ranking
1	89.42%	93.27%
2	89.42%	91.35%
3	79.81%	82.69%
4	82.69%	85.58%
5	72.12%	76.92%
6	76.92%	76.92%
7	68.27%	69.23%
8	70.19%	69.23%
9	67.31%	65.38%
10	70.19%	70.19%

To train ANFIS, the number of clusters are selected randomly. Table(4) shows the training rate and testing rate for best run in case NN and for k=1 on case kNN and best run in case ANFIS before and after applying SFS method on dataset.

Table(4) Best results of three techniques in two cases: before and after execute ranking key method on the features

Technique Name	kNN		ANFIS		NN	
	Before	After	Before	After	Before	After
Training rate	100%	100%	100%	100%	100%	100%
Testing Rate	89.43%	93.27%	76.92%	100%	75%	89.42%

## 7. Conclusions

After many experiments, it is concluded that the using of sequential forward selection method makes three techniques give a good accuracy. From the table no (4), it could be observed that ANFIS gave the best accuracy which is 100%, and 93.27% in case kNN. While in NN we obtained 89.42%. This means, we got a better accuracy comparing with the testing rate before applying sequential forward selection method.

## Reference

- [1] Andrew R. Webb , Statistical Pattern Recognition, 2nd ed. Andrew R. Webb Copyright \_ 2002 John Wiley & Sons, Ltd.
- [2] Aqel, M.M., Jena, R.K., Mahanti, P.K. and Srivastava , Soft Computing Methodologies in Bioinformatics, European Journal of Scientific Research, 2009, vol.26, no 2.
- [3] Pai, G. V and Rajasekaran, S, Neural Networks, Fuzzy Logic and Genetic Algorithms Synthesis and Applications, 6th ed, 2006, Prentice Hall of India Pvt. Ltd.

[4] HazlinaHamdan , An Exploration of the Adaptive Neuro-Fuzzy Inference System (ANFIS) in Modelling Survival ph. D. Thesis ,University of Nottingham Nottingham, United Kingdom March 2013

[5] Daniel T, An Introduction to Data Mining, Copyright C 2005 John Wiley & Sons, Inc.

[6] AmanKataria , M. D. Singh, A Review of Data Classification Using k-Nearest Neighbour Algorithm, (ISSN 2250-2459, ISO 9001:2008 Certified Journal, Volume 3, Issue 6, June 2013).

[7] Hal Daumé , A Course in Machine Learning, Copyright © Hal Daumé III2012.

[8] Alex Smola and S.V.N. Vishwanathan , Introduction to Machine Learning, Copyright C Cambridge University Press 2008.

[9] <http://www.ics.uci.edu/pub/ml-repos/machine-learning-databases/>, 2003.

## Appendix A

IJSER

Features no. and rank no. after execute sequential forward selection with example of one pattern from data set.

Feature no.	Rank no.	EXAMPLE		Feature no.	Rank no.	EXAMPLE	
		Before Rank	After Rank			Before Rank	After Rank
1	11	0.0025	0.2444	42	55	0.2941	0.3717
2	12	0.0309	0.1672	43	60	0.2211	0.3038
3	49	0.0171	0.7272	44	28	0.1524	0.3239
4	45	0.0228	0.241	45	24	0.0746	0.0228
5	10	0.0434	0.3613	46	15	0.0606	0.1661
6	48	0.1224	0.0947	47	39	0.0692	0.143
7	9	0.1947	0.348	48	27	0.0446	0.1224
8	46	0.1661	0.7152	49	32	0.0344	0.0171

9	13	0.1368	0.1947	50	38	0.0082	1
10	47	0.143	0.0434	51	29	0.0108	0.0994
11	51	0.0994	0.0025	52	40	0.0149	0.225
12	52	0.225	0.0309	53	26	0.0077	0.6096
13	1	0.2444	0.1368	54	25	0.0036	0.8516
14	44	0.3239	0.4841	55	41	0.0114	0.2941
15	36	0.3039	0.0606	56	18	0.0085	0.0916
16	4	0.241	0.0101	57	16	0.0101	0.0014
17	21	0.0367	0.0028	58	30	0.0016	0.7102
18	2	0.1672	0.0085	59	17	0.0028	0.2586
19	43	0.3038	0.511	60	57	0.0014	0.2211
20	35	0.4069	0.1994				
21	5	0.3613	0.0367				
22	20	0.1994	0.6849				
23	37	0.4611	0.2287				
24	22	0.6849	0.0746				
25	3	0.7272	0.0036				
26	8	0.7152	0.0077				
27	58	0.7102	0.0446				
28	54	0.8516	0.1524				
29	50	1	0.0108				
30	34	0.769	0.0016				
31	14	0.4841	0.2095				
32	42	0.3717	0.0344				
33	53	0.6096	0.1901				
34	19	0.511	0.769				
35	59	0.2586	0.4069				
36	56	0.0916	0.3039				
37	6	0.0947	0.4611				
38	23	0.2287	0.0082				
39	7	0.348	0.0692				
40	31	0.2095	0.0149				

41	33	0.1901	0.0114				
----	----	--------	--------	--	--	--	--

Appendix B

1 2	1 3	1 4	1 5	1 6	1 7	1 8	1 9	1 10
62.50	62.50	66.35	76.92	77.88	75.96	81.73	77.88	77.88
1 11	1 12	1 13	1 14	1 15	1 16	1 17	1 18	1 19
77.88	77.88	81.73	79.81	80.77	80.77	80.77	80.77	84.62
1 20	1 21	1 22	1 23	1 24	1 25	1 26	1 27	1 28
85.58	85.58	87.50	86.54	87.50	87.50	87.50	87.50	84.62
1 29	1 30	1 31	1 32	1 33	1 34	1 35	1 36	1 37
84.62	84.62	86.54	86.54	86.54	85.58	86.54	87.50	85.58
1 38	1 39	1 40	1 41	1 42	1 43	1 44	1 45	1 46
85.58	85.58	85.58	85.58	85.58	84.62	83.65	83.65	83.65
1 47	1 48	1 49	1 50	1 51	1 52	1 53	1 54	1 55
84.62	84.62	84.62	82.69	87.50	86.54	86.54	90.38	89.42
1 56	1 57	1 58	1 59	1 60			2 3	2 4
89.42	89.42	88.46	88.46	89.42			46.15	58.65
2 5	2 6	2 7	2 8	2 9	2 10	2 11	2 12	2 13
76.92	72.12	76.92	73.08	73.08	73.08	73.08	73.08	75.96
2 14	2 15	2 16	2 17	2 18	2 19	2 20	2 21	2 22
78.85	80.77	80.77	80.77	80.77	84.62	85.58	84.62	87.50
2 23	2 24	2 25	2 26	2 27	2 28	2 29	2 30	2 31
87.50	87.50	87.50	86.54	86.54	86.54	86.54	86.54	85.58
2 32	2 33	2 34	2 35	2 36	2 37	2 38	2 39	2 40
85.58	85.58	85.58	85.58	87.50	83.65	83.65	83.65	83.65
2 41	2 42	2 43	2 44	2 45	2 46	2 47	2 48	2 49
83.65	85.58	86.54	83.65	82.69	83.65	85.58	86.54	86.54
2 50	2 51	2 52	2 53	2 54	2 55	2 56	2 57	2 58
84.62	85.58	86.54	86.54	90.38	89.42	89.42	89.42	89.42
2 59	2 60			3 4	3 5	3 6	3 7	3 8
89.42	89.42			54.81	69.23	69.23	75.00	69.23

3 9	3 10	3 11	3 12	3 13	3 14	3 15	3 16	3 17
71.15	73.08	73.08	74.04	76.92	75.96	77.88	77.88	77.88
3 18	3 19	3 20	3 21	3 22	3 23	3 24	3 25	3 26
77.88	86.54	87.50	86.54	88.46	88.46	85.58	85.58	85.58
3 27	3 28	3 29	3 30	3 31	3 32	3 33	3 34	3 35
87.50	85.58	85.58	85.58	86.54	86.54	85.58	84.62	85.58
3 36	3 37	3 38	3 39	3 40	3 41	3 42	3 43	3 44
87.50	86.54	86.54	85.58	85.58	85.58	87.50	84.62	83.65
3 45	3 46	3 47	3 48	3 49	3 50	3 51	3 52	3 53
83.65	83.65	84.62	84.62	84.62	83.65	85.58	87.50	87.50
3 54	3 55	3 56	3 57	3 58	3 59	3 60		
90.38	89.42	90.38	90.38	90.38	89.42	89.42		
4 5	4 6	4 7	4 8	4 9	4 10	4 11	4 12	4 13
60.58	74.04	69.23	71.15	73.08	74.04	74.04	73.08	77.88
4 14	4 15	4 16	4 17	4 18	4 19	4 20	4 21	4 22
78.85	78.85	78.85	78.85	78.85	85.58	89.42	87.50	89.42
4 23	4 24	4 25	4 26	4 27	4 28	4 29	4 30	4 31
85.58	83.65	83.65	83.65	85.58	86.54	86.54	86.54	88.46
4 32	4 33	4 34	4 35	4 36	4 37	4 38	4 39	4 40
88.46	88.46	85.58	85.58	85.58	87.50	87.50	86.54	86.54
4 41	4 42	4 43	4 44	4 45	4 46	4 47	4 48	4 49
86.54	87.50	86.54	83.65	83.65	84.62	85.58	86.54	86.54
4 50	4 51	4 52	4 53	4 54	4 55	4 56	4 57	4 58
86.54	86.54	87.50	88.46	90.38	89.42	90.38	90.38	89.42
4 59	4 60			5 6	5 7	5 8	5 9	5 10
89.42	90.38			71.15	69.23	71.15	74.04	72.12
5 11	5 12	5 13	5 14	5 15	5 16	5 17	5 18	5 19
72.12	72.12	81.73	76.92	77.88	77.88	77.88	77.88	86.54
5 20	5 21	5 22	5 23	5 24	5 25	5 26	5 27	5 28
87.50	87.50	88.46	87.50	89.42	89.42	89.42	88.46	85.58
5 29	5 30	5 31	5 32	5 33	5 34	5 35	5 36	5 37
85.58	85.58	87.50	87.50	87.50	84.62	84.62	85.58	85.58

5 38	5 39	5 40	5 41	5 42	5 43	5 44	5 45	5 46
85.58	84.62	84.62	84.62	85.58	85.58	85.58	85.58	85.58
5 47	5 48	5 49	5 50	5 51	5 52	5 53	<b>5 54</b>	5 55
87.50	88.46	88.46	85.58	86.54	88.46	90.38	<b>91.35</b>	90.38
5 56	5 57	5 58	5 59	5 60			6 7	6 8
90.38	90.38	90.38	90.38	90.38			52.88	57.69
6 9	6 10	6 11	6 12	6 13	6 14	6 15	6 16	6 17
65.38	65.38	66.35	68.27	76.92	77.88	81.73	81.73	81.73
6 18	6 19	6 20	6 21	6 22	6 23	6 24	6 25	6 26
81.73	82.69	87.50	87.50	86.54	85.58	82.69	82.69	82.69
6 27	6 28	6 29	6 30	6 31	6 32	6 33	6 34	6 35
83.65	80.77	80.77	80.77	84.62	84.62	87.50	82.69	88.46
6 36	6 37	6 38	6 39	6 40	6 41	6 42	6 43	6 44
88.46	86.54	86.54	85.58	85.58	85.58	87.50	87.50	88.46
6 45	6 46	6 47	6 48	6 49	6 50	6 51	6 52	6 53
88.46	88.46	89.42	89.42	89.42	86.54	88.46	88.46	90.38
6 54	6 55	6 56	6 57	6 58	6 59	6 60		
91.35	91.35	90.38	90.38	90.38	90.38	90.38		
7 8	7 9	7 10	7 11	7 12	7 13	7 14	7 15	7 16
44.23	51.92	57.69	54.81	56.73	66.35	66.35	75.96	75.96
7 17	7 18	7 19	7 20	7 21	7 22	7 23	7 24	7 25
75.96	75.96	76.92	85.58	80.77	79.81	81.73	81.73	81.73
7 26	7 27	7 28	7 29	7 30	7 31	7 32	7 33	7 34
81.73	82.69	78.85	78.85	78.85	81.73	81.73	82.69	77.88
7 35	7 36	7 37	7 38	7 39	7 40	7 41	7 42	7 43
85.58	85.58	82.69	82.69	82.69	82.69	82.69	85.58	84.62
7 44	7 45	7 46	7 47	7 48	7 49	7 50	7 51	7 52
85.58	85.58	85.58	87.50	87.50	87.50	83.65	86.54	85.58
7 53	7 54	7 55	7 56	7 57	7 58	7 59	7 60	
86.54	88.46	89.42	90.38	90.38	88.46	89.42	90.38	
	8 9	8 10	8 11	8 12	8 13	8 14	8 15	8 16
	47.12	54.81	58.65	59.62	68.27	67.31	72.12	72.12

8 17	8 18	8 19	8 20	8 21	8 22	8 23	8 24	8 25
72.12	72.12	75.00	79.81	81.73	81.73	81.73	82.69	82.69
8 26	8 27	8 28	8 29	8 30	8 31	8 32	8 33	8 34
82.69	83.65	79.81	79.81	79.81	79.81	79.81	82.69	79.81
8 35	8 36	8 37	8 38	8 39	8 40	8 41	8 42	8 43
86.54	87.50	84.62	84.62	85.58	85.58	85.58	84.62	83.65
8 44	8 45	8 46	8 47	8 48	8 49	8 50	8 51	8 52
85.58	85.58	85.58	87.50	87.50	87.50	86.54	86.54	86.54
8 53	8 54	8 55	8 56	8 57	8 58	8 59	8 60	
87.50	90.38	89.42	89.42	89.42	88.46	89.42	89.42	
	9 10	9 11	9 12	9 13	9 14	9 15	9 16	9 17
	50.96	53.85	51.92	70.19	62.50	66.35	66.35	66.35
9 18	9 19	9 20	9 21	9 22	9 23	9 24	9 25	9 26
66.35	75.96	73.08	80.77	78.85	76.92	76.92	76.92	76.92
9 27	9 28	9 29	9 30	9 31	9 32	9 33	9 34	9 35
77.88	75.96	75.96	75.96	79.81	80.77	82.69	79.81	86.54
9 36	9 37	9 38	9 39	9 40	9 41	9 42	9 43	9 44
86.54	87.50	87.50	87.50	87.50	87.50	84.62	82.69	84.62
9 45	9 46	9 47	9 48	9 49	9 50	9 51	9 52	9 53
85.58	85.58	87.50	87.50	86.54	88.46	87.50	87.50	87.50
9 54	9 55	9 56	9 57	9 58	9 59	9 60		
90.38	89.42	90.38	90.38	89.42	89.42	89.42		
10 11	10 12	10 13	10 14	10 15	10 16	10 17	10 18	10 19
59.62	58.65	59.62	67.31	67.31	66.35	66.35	66.35	81.73
10 20	10 21	10 22	10 23	10 24	10 25	10 26	10 27	10 28
75.00	81.73	79.81	78.85	77.88	77.88	77.88	78.85	77.88
10 29	10 30	10 31	10 32	10 33	10 34	10 35	10 36	10 37
77.88	77.88	80.77	80.77	82.69	79.81	85.58	86.54	86.54
10 38	10 39	10 40	10 41	10 42	10 43	10 44	10 45	10 46
86.54	85.58	86.54	86.54	84.62	81.73	83.65	83.65	84.62
10 47	10 48	10 49	10 50	10 51	10 52	10 53	10 54	10 55
87.50	87.50	86.54	88.46	87.50	86.54	87.50	90.38	89.42



10 56	10 57	10 58	10 59	10 60			11 12	11 13
90.38	90.38	89.42	89.42	89.42			50.96	58.65
11 14	11 15	11 16	11 17	11 18	11 19	11 20	11 21	11 22
62.50	61.54	62.50	62.50	62.50	75.00	75.96	81.73	79.81
11 23	11 24	11 25	11 26	11 27	11 28	11 29	11 30	11 31
78.85	78.85	78.85	78.85	78.85	78.85	78.85	78.85	77.88
11 32	11 33	11 34	11 35	11 36	11 37	11 38	11 39	11 40
78.85	82.69	79.81	86.54	85.58	87.50	87.50	86.54	86.54
11 41	11 42	11 43	11 44	11 45	11 46	11 47	11 48	11 49
86.54	84.62	81.73	83.65	83.65	84.62	87.50	87.50	86.54
11 50	11 51	11 52	11 53	11 54	11 55	11 56	11 57	11 58
88.46	87.50	87.50	87.50	90.38	89.42	90.38	90.38	89.42
11 59	11 60			12 13	12 14	12 15	12 16	12 17
89.42	89.42			58.65	66.35	61.54	62.50	62.50
12 18	12 19	12 20	12 21	12 22	12 23	12 24	12 25	12 26
62.50	74.04	75.96	81.73	79.81	78.85	78.85	78.85	78.85
12 27	12 28	12 29	12 30	12 31	12 32	12 33	12 34	12 35
78.85	78.85	78.85	78.85	77.88	78.85	81.73	79.81	86.54
12 36	12 37	12 38	12 39	12 40	12 41	12 42	12 43	12 44
85.58	87.50	87.50	86.54	86.54	86.54	84.62	81.73	83.65
12 45	12 46	12 47	12 48	12 49	12 50	12 51	12 52	12 53
83.65	84.62	87.50	87.50	86.54	88.46	87.50	87.50	87.50
12 54	12 55	12 56	12 57	12 58	12 59	12 60		
90.38	89.42	90.38	90.38	89.42	89.42	89.42		
13 14	13 15	13 16	13 17	13 18	13 19	13 20	13 21	13 22
64.42	66.35	66.35	65.38	64.42	73.08	75.96	81.73	79.81
13 23	13 24	13 25	13 26	13 27	13 28	13 29	13 30	13 31
77.88	77.88	77.88	77.88	78.85	78.85	78.85	78.85	77.88
13 32	13 33	13 34	13 35	13 36	13 37	13 38	13 39	13 40
78.85	81.73	79.81	86.54	85.58	87.50	86.54	86.54	86.54
13 41	13 42	13 43	13 44	13 45	13 46	13 47	13 48	13 49
86.54	84.62	81.73	83.65	83.65	84.62	87.50	87.50	86.54

13 50	13 51	13 52	13 53	13 54	13 55	13 56	13 57	13 58
88.46	87.50	87.50	87.50	90.38	89.42	89.42	89.42	89.42
13 59	13 60			14 15	14 16	14 17	14 18	14 19
89.42	89.42			55.77	56.73	54.81	54.81	63.46
14 20	14 21	14 22	14 23	14 24	14 25	14 26	14 27	14 28
75.00	76.92	73.08	72.12	74.04	74.04	74.04	73.08	74.04
14 29	14 30	14 31	14 32	14 33	14 34	14 35	14 36	14 37
74.04	74.04	75.96	75.96	78.85	76.92	85.58	84.62	83.65
14 38	14 39	14 40	14 41	14 42	14 43	14 44	14 45	14 46
83.65	84.62	84.62	84.62	82.69	82.69	83.65	83.65	85.58
14 47	14 48	14 49	14 50	14 51	14 52	14 53	14 54	14 55
86.54	86.54	86.54	88.46	86.54	87.50	88.46	89.42	88.46
14 56	14 57	14 58	14 59	14 60			15 16	15 17
89.42	89.42	89.42	89.42	89.42			52.88	50.00
15 18	15 19	15 20	15 21	15 22	15 23	15 24	15 25	15 26
51.92	63.46	60.58	71.15	68.27	68.27	69.23	69.23	69.23
15 27	15 28	15 29	15 30	15 31	15 32	15 33	15 34	15 35
69.23	69.23	69.23	69.23	75.96	75.96	79.81	75.00	79.81
15 36	15 37	15 38	15 39	15 40	15 41	15 42	15 43	15 44
81.73	78.85	78.85	78.85	78.85	78.85	81.73	80.77	80.77
15 45	15 46	15 47	15 48	15 49	15 50	15 51	15 52	15 53
79.81	81.73	84.62	85.58	85.58	86.54	86.54	87.50	88.46
15 54	15 55	15 56	15 57	15 58	15 59	15 60		
88.46	87.50	89.42	89.42	88.46	88.46	88.46		
16 17	16 18	16 19	16 20	16 21	16 22	16 23	16 24	16 25
45.19	52.88	54.81	51.92	65.38	60.58	64.42	66.35	66.35
16 26	16 27	16 28	16 29	16 30	16 31	16 32	16 33	16 34
66.35	67.31	68.27	68.27	67.31	74.04	74.04	81.73	77.88
16 35	16 36	16 37	16 38	16 39	16 40	16 41	16 42	16 43
79.81	81.73	78.85	78.85	78.85	78.85	78.85	82.69	81.73
16 44	16 45	16 46	16 47	16 48	16 49	16 50	16 51	16 52
81.73	80.77	82.69	84.62	85.58	85.58	86.54	86.54	86.54

16 53 87.50	16 54 88.46	16 55 87.50	16 56 88.46	16 57 88.46	16 58 88.46	16 59 87.50	16 60 86.54	
	17 18 59.62	17 19 56.73	17 20 51.92	17 21 65.38	17 22 60.58	17 23 64.42	17 24 66.35	17 25 66.35
17 26 66.35	17 27 67.31	17 28 68.27	17 29 68.27	17 30 67.31	17 31 74.04	17 32 74.04	17 33 81.73	17 34 77.88
17 35 79.81	17 36 81.73	17 37 78.85	17 38 78.85	17 39 78.85	17 40 78.85	17 41 78.85	17 42 82.69	17 43 81.73
17 44 81.73	17 45 80.77	17 46 82.69	17 47 84.62	17 48 85.58	17 49 85.58	17 50 86.54	17 51 86.54	17 52 86.54
17 53 87.50	17 54 88.46	17 55 87.50	17 56 88.46	17 57 88.46	17 58 88.46	17 59 87.50	17 60 86.54	
	18 19 51.92	18 20 51.92	18 21 65.38	18 22 60.58	18 23 64.42	18 24 66.35	18 25 66.35	18 26 66.35
18 27 67.31	18 28 68.27	18 29 68.27	18 30 68.27	18 31 74.04	18 32 74.04	18 33 81.73	18 34 76.92	18 35 79.81
18 36 81.73	18 37 78.85	18 38 78.85	18 39 78.85	18 40 78.85	18 41 78.85	18 42 82.69	18 43 81.73	18 44 81.73
18 45 80.77	18 46 82.69	18 47 84.62	18 48 85.58	18 49 85.58	18 50 86.54	18 51 86.54	18 52 86.54	18 53 87.50
18 54 88.46	18 55 87.50	18 56 88.46	18 57 88.46	18 58 88.46	18 59 87.50	18 60 86.54		
19 20 51.92	19 21 65.38	19 22 60.58	19 23 64.42	19 24 66.35	19 25 66.35	19 26 66.35	19 27 67.31	19 28 68.27
19 29 68.27	19 30 68.27	19 31 74.04	19 32 74.04	19 33 81.73	19 34 77.88	19 35 79.81	19 36 81.73	19 37 78.85
19 38 78.85	19 39 78.85	19 40 78.85	19 41 78.85	19 42 82.69	19 43 81.73	19 44 81.73	19 45 80.77	19 46 82.69
19 47 84.62	19 48 85.58	19 49 85.58	19 50 86.54	19 51 86.54	19 52 86.54	19 53 87.50	19 54 88.46	19 55 87.50
19 56 88.46	19 57 88.46	19 58 88.46	19 59 87.50	19 60 86.54			20 21 57.69	20 22 58.65

20 23	20 24	20 25	20 26	20 27	20 28	20 29	20 30	20 31
65.38	69.23	69.23	69.23	70.19	72.12	72.12	72.12	77.88
20 32	20 33	20 34	20 35	20 36	20 37	20 38	20 39	20 40
77.88	86.54	75.00	75.96	76.92	75.96	75.96	76.92	76.92
20 41	20 42	20 43	20 44	20 45	20 46	20 47	20 48	20 49
76.92	79.81	76.92	75.96	76.92	78.85	83.65	83.65	83.65
20 50	20 51	20 52	20 53	20 54	20 55	20 56	20 57	20 58
85.58	85.58	85.58	87.50	87.50	85.58	86.54	86.54	85.58
20 59	20 60			21 22	21 23	21 24	21 25	21 26
88.46	86.54			50.96	59.62	65.38	67.31	66.35
21 27	21 28	21 29	21 30	21 31	21 32	21 33	21 34	21 35
68.27	70.19	70.19	70.19	77.88	75.96	82.69	75.96	79.81
21 36	21 37	21 38	21 39	21 40	21 41	21 42	21 43	21 44
76.92	75.96	75.96	75.96	75.96	75.96	77.88	77.88	75.96
21 45	21 46	21 47	21 48	21 49	21 50	21 51	21 52	21 53
75.96	76.92	82.69	81.73	81.73	80.77	82.69	83.65	83.65
21 54	21 55	21 56	21 57	21 58	21 59	21 60		
85.58	84.62	86.54	86.54	88.46	88.46	86.54		
22 23	22 24	22 25	22 26	22 27	22 28	22 29	22 30	22 31
54.81	59.62	59.62	58.65	65.38	67.31	65.38	65.38	68.27
22 32	22 33	22 34	22 35	22 36	22 37	22 38	22 39	22 40
70.19	77.88	73.08	76.92	79.81	78.85	78.85	78.85	78.85
22 41	22 42	22 43	22 44	22 45	22 46	22 47	22 48	22 49
78.85	80.77	80.77	80.77	80.77	80.77	80.77	81.73	81.73
22 50	22 51	22 52	22 53	22 54	22 55	22 56	22 57	22 58
78.85	77.88	81.73	82.69	83.65	82.69	87.50	87.50	87.50
22 59	22 60			23 24	23 25	23 26	23 27	23 28
88.46	85.58			61.54	62.50	63.46	72.12	61.54
23 29	23 30	23 31	23 32	23 33	23 34	23 35	23 36	23 37
61.54	61.54	63.46	66.35	69.23	71.15	75.00	74.04	80.77
23 38	23 39	23 40	23 41	23 42	23 43	23 44	23 45	23 46
80.77	81.73	81.73	81.73	83.65	83.65	82.69	82.69	81.73

23 47 82.69	23 48 82.69	23 49 81.73	23 50 80.77	23 51 81.73	23 52 83.65	23 53 85.58	23 54 84.62	23 55 84.62
23 56 89.42	23 57 89.42	23 58 90.38	23 59 88.46	23 60 88.46			24 25 56.73	24 26 51.92
24 27 61.54	24 28 61.54	24 29 58.65	24 30 61.54	24 31 66.35	24 32 66.35	24 33 65.38	24 34 69.23	24 35 72.12
24 36 72.12	24 37 78.85	24 38 78.85	24 39 76.92	24 40 76.92	24 41 76.92	24 42 78.85	24 43 80.77	24 44 79.81
24 45 80.77	24 46 80.77	24 47 83.65	24 48 83.65	24 49 82.69	24 50 81.73	24 51 80.77	24 52 81.73	24 53 86.54
24 54 85.58	24 55 84.62	24 56 88.46	24 57 88.46	24 58 88.46	24 59 88.46	24 60 88.46		
25 26 51.92	25 27 65.38	25 28 52.88	25 29 50.00	25 30 50.96	25 31 66.35	25 32 65.38	25 33 68.27	25 34 71.15
25 35 73.08	25 36 74.04	25 37 78.85	25 38 78.85	25 39 78.85	25 40 78.85	25 41 78.85	25 42 79.81	25 43 79.81
25 44 76.92	25 45 77.88	25 46 78.85	25 47 81.73	25 48 81.73	25 49 82.69	25 50 77.88	25 51 79.81	25 52 81.73
25 53 84.62	25 54 85.58	25 55 83.65	25 56 86.54	25 57 86.54	25 58 87.50	25 59 87.50	25 60 86.54	
	26 27 59.62	26 28 50.96	26 29 50.96	26 30 50.00	26 31 64.42	26 32 65.38	26 33 67.31	26 34 71.15
26 35 73.08	26 36 74.04	26 37 78.85	26 38 78.85	26 39 78.85	26 40 78.85	26 41 78.85	26 42 79.81	26 43 78.85
26 44 76.92	26 45 77.88	26 46 78.85	26 47 81.73	26 48 81.73	26 49 82.69	26 50 77.88	26 51 79.81	26 52 81.73
26 53 84.62	26 54 85.58	26 55 83.65	26 56 86.54	26 57 86.54	26 58 87.50	26 59 87.50	26 60 86.54	
	27 28 55.77	27 29 51.92	27 30 52.88	27 31 64.42	27 32 65.38	27 33 66.35	27 34 71.15	27 35 73.08
27 36 74.04	27 37 78.85	27 38 78.85	27 39 78.85	27 40 78.85	27 41 78.85	27 42 79.81	27 43 79.81	27 44 77.88

27 45 77.88	27 46 78.85	27 47 81.73	27 48 81.73	27 49 82.69	27 50 77.88	27 51 79.81	27 52 81.73	27 53 84.62
27 54 85.58	27 55 83.65	27 56 86.54	27 57 86.54	27 58 87.50	27 59 87.50	27 60 86.54		
28 29 47.12	28 30 42.31	28 31 54.81	28 32 54.81	28 33 62.50	28 34 71.15	28 35 70.19	28 36 73.08	28 37 75.96
28 38 75.96	28 39 76.92	28 40 76.92	28 41 76.92	28 42 78.85	28 43 77.88	28 44 76.92	28 45 77.88	28 46 78.85
28 47 80.77	28 48 80.77	28 49 80.77	28 50 77.88	28 51 78.85	28 52 80.77	28 53 82.69	28 54 84.62	28 55 82.69
28 56 86.54	28 57 86.54	28 58 87.50	28 59 87.50	28 60 86.54			29 30 60.58	29 31 54.81
29 32 64.42	29 33 58.65	29 34 72.12	29 35 67.31	29 36 69.23	29 37 74.04	29 38 73.08	29 39 76.92	29 40 76.92
29 41 76.92	29 42 75.00	29 43 77.88	29 44 75.96	29 45 75.00	29 46 75.96	29 47 76.92	29 48 76.92	29 49 76.92
29 50 77.88	29 51 77.88	29 52 81.73	29 53 81.73	29 54 82.69	29 55 80.77	29 56 88.46	29 57 87.50	29 58 85.58
29 59 87.50	29 60 85.58			30 31 54.81	30 32 65.38	30 33 58.65	30 34 72.12	30 35 67.31
30 36 69.23	30 37 74.04	30 38 73.08	30 39 76.92	30 40 76.92	30 41 76.92	30 42 75.00	30 43 77.88	30 44 75.00
30 45 75.00	30 46 75.96	30 47 76.92	30 48 76.92	30 49 76.92	30 50 77.88	30 51 77.88	30 52 81.73	30 53 81.73
30 54 82.69	30 55 80.77	30 56 87.50	30 57 87.50	30 58 85.58	30 59 87.50	30 60 85.58		
31 32 64.42	31 33 58.65	31 34 73.08	31 35 67.31	31 36 69.23	31 37 74.04	31 38 73.08	31 39 76.92	31 40 76.92
31 41 76.92	31 42 75.00	31 43 77.88	31 44 75.00	31 45 75.00	31 46 75.96	31 47 76.92	31 48 76.92	31 49 76.92
31 50 77.88	31 51 77.88	31 52 81.73	31 53 81.73	31 54 82.69	31 55 80.77	31 56 87.50	31 57 87.50	31 58 85.58

31 59 87.50	31 60 85.58			32 33 63.46	32 34 62.50	32 35 61.54	32 36 72.12	32 37 74.04
32 38 73.08	32 39 74.04	32 40 74.04	32 41 74.04	32 42 80.77	32 43 75.96	32 44 75.00	32 45 75.00	32 46 74.04
32 47 75.96	32 48 76.92	32 49 75.96	32 50 78.85	32 51 76.92	32 52 79.81	32 53 78.85	32 54 78.85	32 55 78.85
32 56 86.54	32 57 86.54	32 58 87.50	32 59 85.58	32 60 85.58			33 34 58.65	33 35 58.65
33 36 72.12	33 37 70.19	33 38 69.23	33 39 73.08	33 40 73.08	33 41 73.08	33 42 78.85	33 43 75.00	33 44 74.04
33 45 75.00	33 46 73.08	33 47 75.96	33 48 76.92	33 49 75.96	33 50 78.85	33 51 76.92	33 52 79.81	33 53 78.85
33 54 78.85	33 55 78.85	33 56 86.54	33 57 86.54	33 58 87.50	33 59 85.58	33 60 84.62		
34 35 50.00	34 36 61.54	34 37 68.27	34 38 67.31	34 39 70.19	34 40 70.19	34 41 70.19	34 42 75.00	34 43 72.12
34 44 73.08	34 45 73.08	34 46 73.08	34 47 75.00	34 48 75.00	34 49 75.00	34 50 72.12	34 51 70.19	34 52 73.08
34 53 74.04	34 54 75.00	34 55 78.85	34 56 83.65	34 57 83.65	34 58 84.62	34 59 83.65	34 60 84.62	
	35 36 63.46	35 37 64.42	35 38 65.38	35 39 71.15	35 40 71.15	35 41 71.15	35 42 72.12	35 43 73.08
35 44 74.04	35 45 72.12	35 46 74.04	35 47 78.85	35 48 77.88	35 49 77.88	35 50 75.00	35 51 76.92	35 52 78.85
35 53 77.88	35 54 73.08	35 55 77.88	35 56 80.77	35 57 80.77	35 58 84.62	35 59 82.69	35 60 84.62	
	36 37 54.81	36 38 56.73	36 39 62.50	36 40 61.54	36 41 61.54	36 42 67.31	36 43 65.38	36 44 67.31
36 45 68.27	36 46 70.19	36 47 74.04	36 48 75.96	36 49 75.96	36 50 77.88	36 51 78.85	36 52 75.96	36 53 77.88
36 54 74.04	36 55 79.81	36 56 81.73	36 57 81.73	36 58 82.69	36 59 84.62	36 60 84.62		

37 38 51.92	37 39 60.58	37 40 60.58	37 41 60.58	37 42 62.50	37 43 69.23	37 44 68.27	37 45 69.23	37 46 72.12
37 47 71.15	37 48 72.12	37 49 72.12	37 50 75.96	37 51 78.85	37 52 79.81	37 53 78.85	37 54 77.88	37 55 82.69
37 56 82.69	37 57 82.69	37 58 84.62	37 59 83.65	37 60 84.62			38 39 53.85	38 40 52.88
38 41 53.85	38 42 53.85	38 43 64.42	38 44 64.42	38 45 65.38	38 46 65.38	38 47 74.04	38 48 73.08	38 49 73.08
38 50 76.92	38 51 79.81	38 52 79.81	38 53 78.85	38 54 76.92	38 55 80.77	38 56 85.58	38 57 85.58	38 58 82.69
38 59 85.58	38 60 86.54							
39 40 53.85	39 41 57.69	39 42 57.69	39 43 64.42	39 44 63.46	39 45 65.38	39 46 67.31	39 47 74.04	39 48 73.08
39 49 73.08	39 50 76.92	39 51 79.81	39 52 79.81	39 53 78.85	39 54 76.92	39 55 80.77	39 56 85.58	39 57 85.58
39 58 82.69	39 59 85.58	39 60 86.54			40 41 62.50	40 42 61.54	40 43 61.54	40 44 60.58
40 45 60.58	40 46 57.69	40 47 67.31	40 48 66.35	40 49 66.35	40 50 73.08	40 51 77.88	40 52 75.96	40 53 78.85
40 54 75.00	40 55 78.85	40 56 82.69	40 57 82.69	40 58 82.69	40 59 84.62	40 60 85.58		
41 42 55.77	41 43 62.50	41 44 61.54	41 45 60.58	41 46 57.69	41 47 66.35	41 48 66.35	41 49 66.35	41 50 73.08
41 51 77.88	41 52 75.96	41 53 78.85	41 54 75.00	41 55 78.85	41 56 82.69	41 57 82.69	41 58 82.69	41 59 84.62
41 60 84.62			42 43 62.50	42 44 61.54	42 45 60.58	42 46 57.69	42 47 67.31	42 48 66.35
42 49 66.35	42 50 73.08	42 51 77.88	42 52 75.96	42 53 78.85	42 54 75.00	42 55 78.85	42 56 82.69	42 57 82.69
42 58 82.69	42 59 84.62	42 60 84.62			43 44 51.92	43 45 50.96	43 46 55.77	43 47 61.54



43 48 62.50	43 49 65.38	43 50 68.27	43 51 74.04	43 52 74.04	43 53 76.92	43 54 70.19	43 55 77.88	43 56 85.58
43 57 85.58	43 58 80.77	43 59 82.69	43 60 83.65			44 45 53.85	44 46 61.54	44 47 59.62
44 48 60.58	44 49 62.50	44 50 69.23	44 51 73.08	44 52 71.15	44 53 79.81	44 54 79.81	44 55 77.88	44 56 85.58
44 57 85.58	44 58 85.58	44 59 83.65	44 60 86.54			45 46 59.62	45 47 60.58	45 48 61.54
45 49 59.62	45 50 67.31	45 51 66.35	45 52 66.35	45 53 75.96	45 54 74.04	45 55 72.12	45 56 82.69	45 57 82.69
45 58 84.62	45 59 80.77	45 60 85.58			46 47 59.62	46 48 53.85	46 49 56.73	46 50 62.50
46 51 62.50	46 52 65.38	46 53 76.92	46 54 74.04	46 55 70.19	46 56 82.69	46 57 82.69	46 58 84.62	46 59 80.77
46 60 85.58			47 48 59.62	47 49 62.50	47 50 62.50	47 51 61.54	47 52 64.42	47 53 75.00
47 54 73.08	47 55 72.12	47 56 79.81	47 57 79.81	47 58 84.62	47 59 80.77	47 60 84.62		
48 49 42.31	48 50 58.65	48 51 60.58	48 52 60.58	48 53 74.04	48 54 73.08	48 55 73.08	48 56 77.88	48 57 77.88
48 58 86.54	48 59 80.77	48 60 81.73			49 50 61.54	49 51 64.42	49 52 63.46	49 53 70.19
49 54 72.12	49 55 73.08	49 56 78.85	49 57 78.85	49 58 82.69	49 59 78.85	49 60 80.77		
50 51 65.38	50 52 65.38	50 53 71.15	50 54 72.12	50 55 73.08	50 56 78.85	50 57 78.85	50 58 82.69	50 59 80.77
50 60 80.77			51 52 67.31	51 53 65.38	51 54 68.27	51 55 70.19	51 56 76.92	51 57 76.92
51 58 77.88	51 59 76.92	51 60 79.81			52 53 62.50	52 54 65.38	52 55 68.27	52 56 76.92
52 57 76.92	52 58 78.85	52 59 76.92	52 60 81.73			53 54 57.69	53 55 58.65	53 56 70.19

53 57 70.19	53 58 70.19	53 59 71.15	53 60 73.08			54 55 61.54	54 56 61.54	54 57 61.54
54 58 62.50	54 59 64.42	54 60 70.19			55 56 63.46	55 57 63.46	55 58 64.42	55 59 64.42
55 60 65.38			56 57 55.77	56 58 61.54	56 59 57.69	56 60 67.31		
57 58 45.19	57 59 44.23	57 60 66.35			58 59 44.23	58 60 65.38		
59 60 60.58								

IJSER